

Regular and irregular polygons

1 Measure and label the sides and angles of each shape.

a)

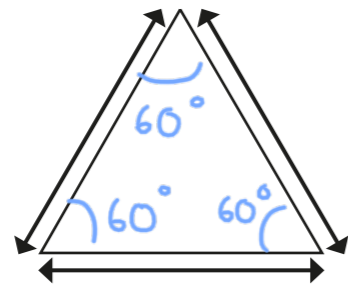

Side lengths depend on how the sheets are printed.

b)

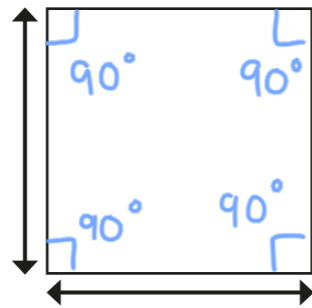

c)

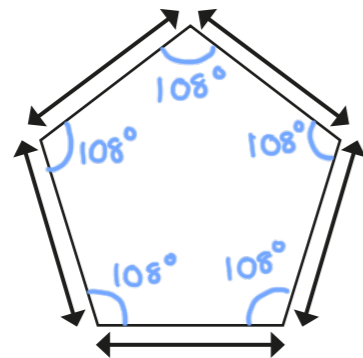

What do you notice about your answers?

These are all examples of regular polygons.

Explain in your own words what a regular polygon is.

2 Measure and label the sides and angles of each shape.

a)

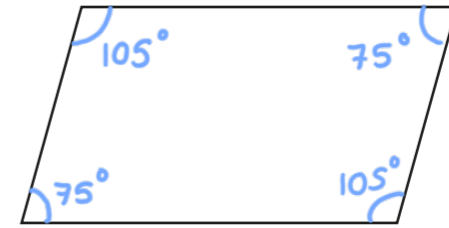

b)

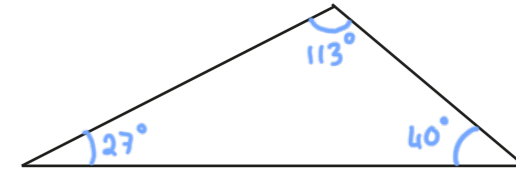

c)

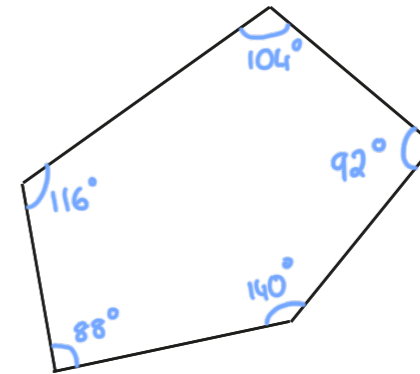

What do you notice about your answers?

These are all examples of irregular polygons.

Explain in your own words what an irregular polygon is.

A polygon where the sides and angles are not all equal.

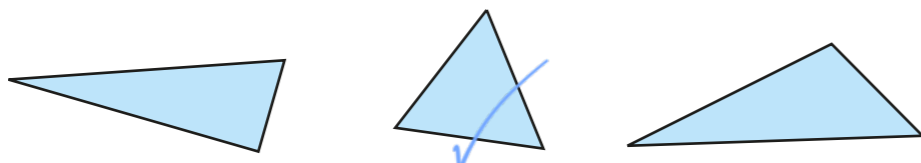

3 One polygon in each set is regular. Tick the regular polygon.

a) 

b) 

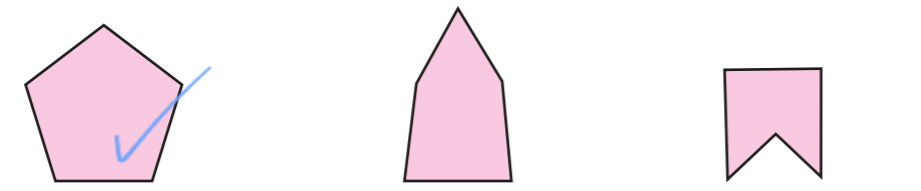
c) 

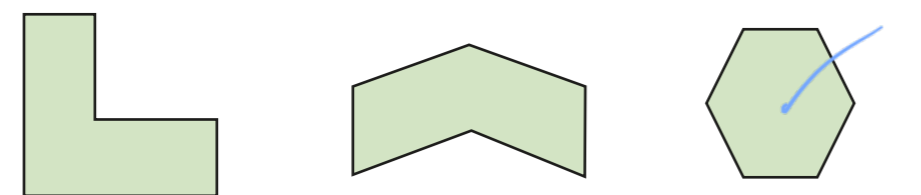
d) 

How did you know which one was regular without measuring?

4 Draw two regular and two irregular polygons on the grid.

e.g.

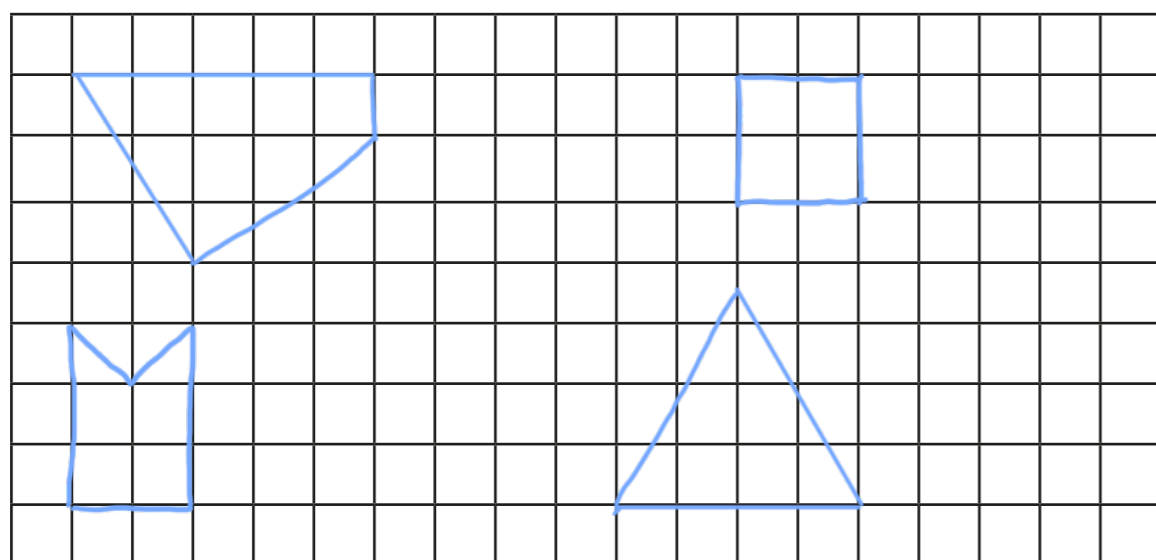

Compare your polygons with a partner.

What is the same and what is different?

5 Here is a rhombus.

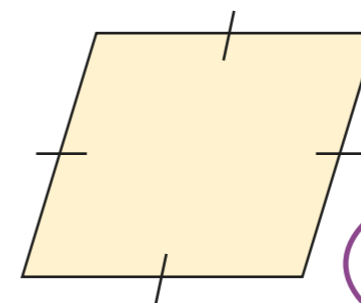

This is a regular polygon because all the sides are the same length.

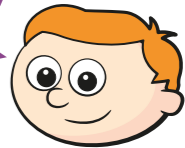

Do you agree with Ron? No

Explain your answer.

The angles are not all equal.

6 Eva has drawn a square and a regular pentagon.

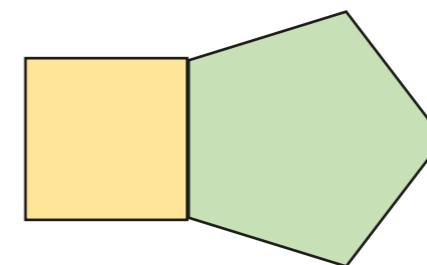

The compound shape is regular because both of the shapes I drew were regular.

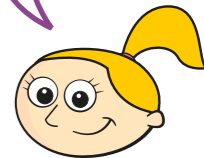

Do you agree with Eva? No

Explain your answer.

Reasoning about 3D shapes



1 Match the net to the correct label.

cube

cylinder

square-based pyramid

cuboid

2 Complete the sentences.

a) The faces of a cube are all square.

b) A square-based pyramid has triangular faces and square face.

c) The net of a cylinder is made up of 2 circles and a rectangle.

3



Whitney

The net of a cuboid is made up of 4 rectangles and 2 squares.

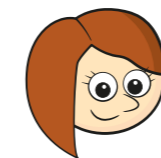

Rosie

The net of a cuboid is made up of 6 rectangles.

Who do you agree with? Circle your answer.

Whitney

Rosie

both of them

Explain your reasons.

Whitney is sometimes right if a cuboid has square faces. Rosie is always right as a square is a type of rectangle.

4 Tick the diagram that is the net of a cone.

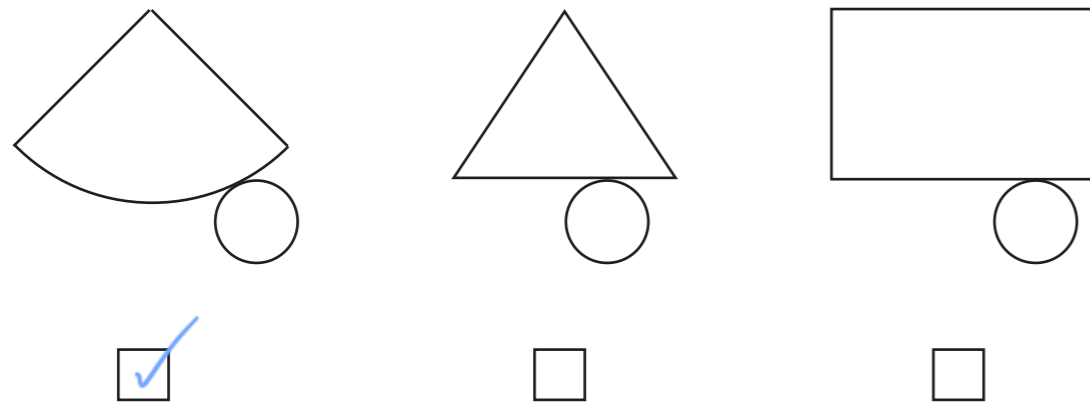

Compare answers with a partner.

5 Draw the net for a triangular prism on the squared grid.

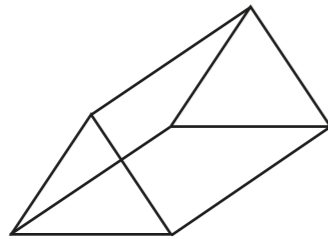

e.g.

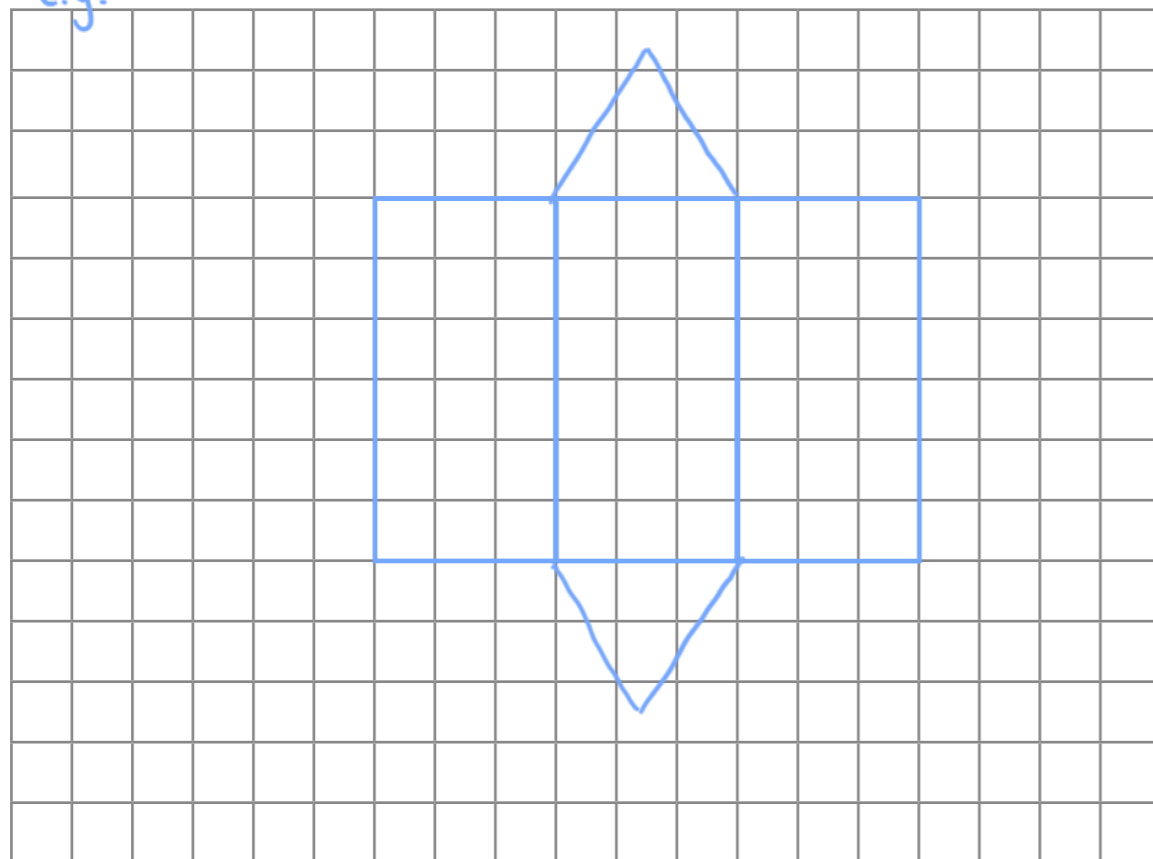

6 Draw an **accurate** net for this cuboid on the squared grid.

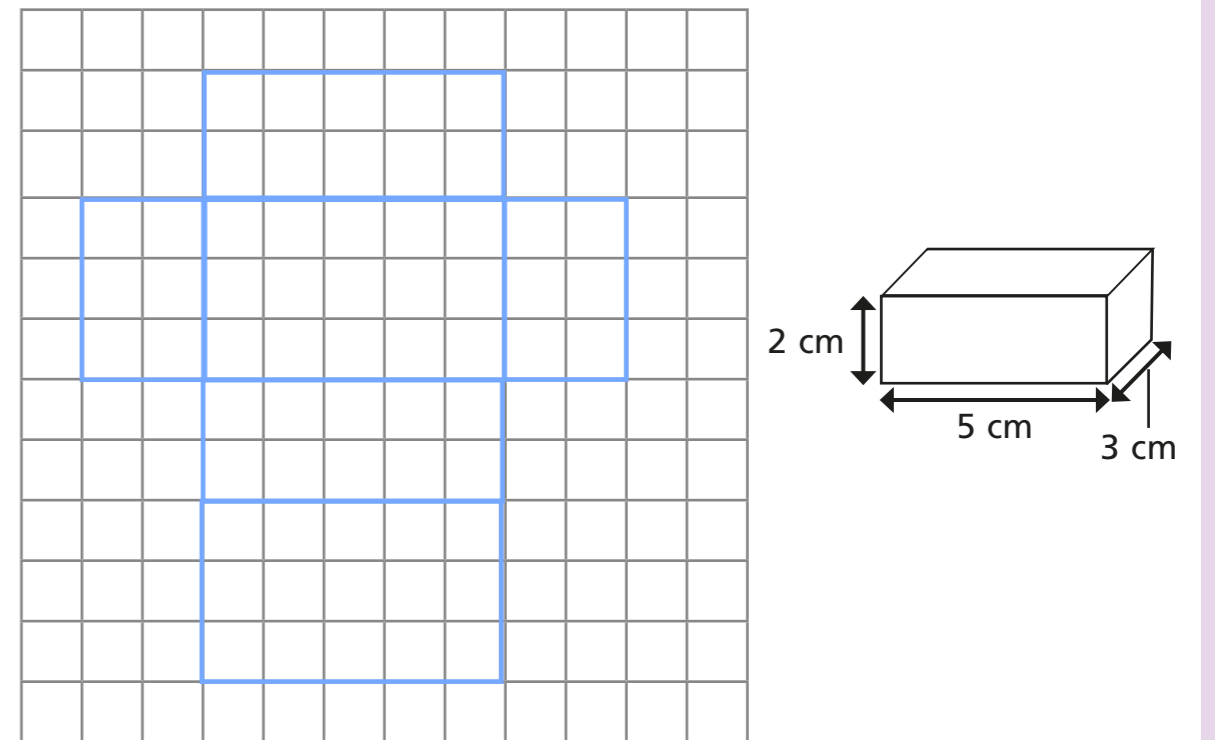

7 Draw two different cuboids on the isometric paper.

e.g.

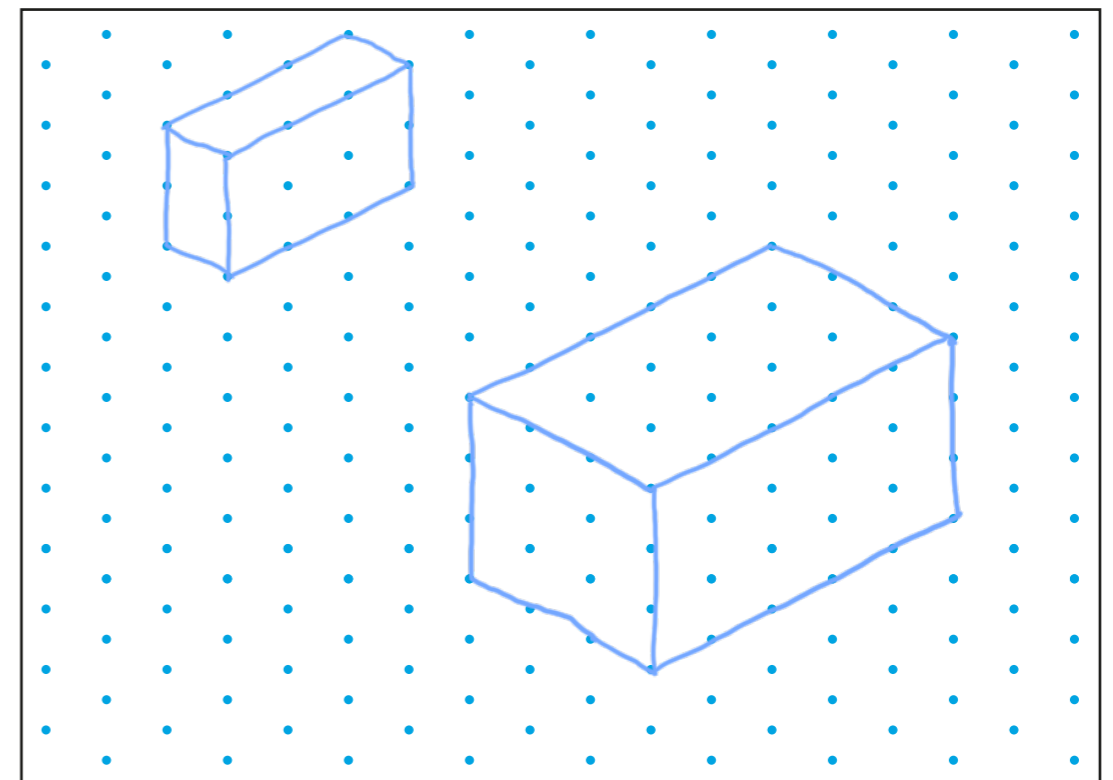



1 Reflect each shape in the mirror line.

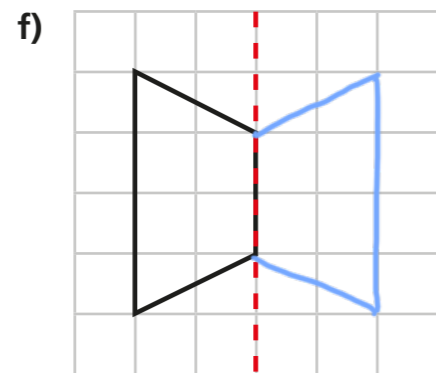
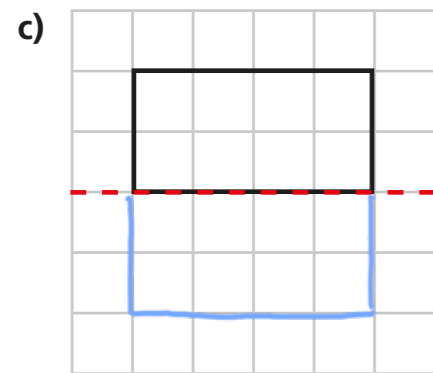
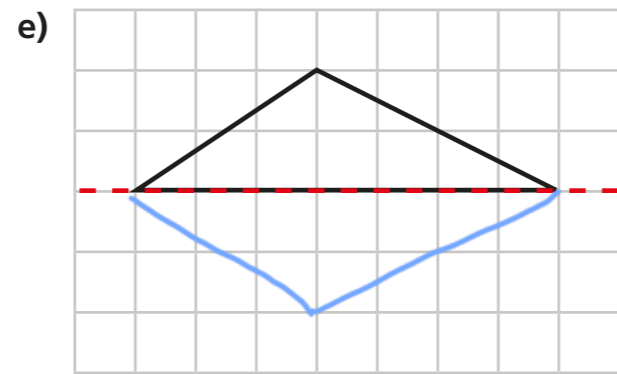
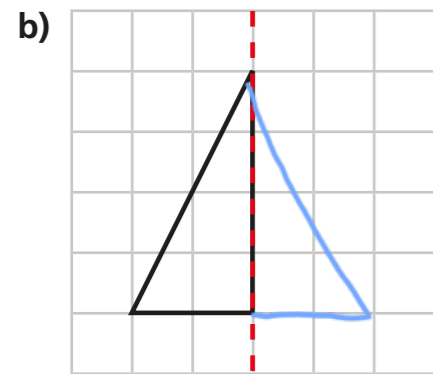
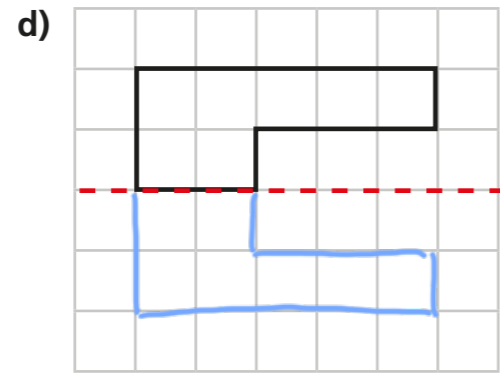
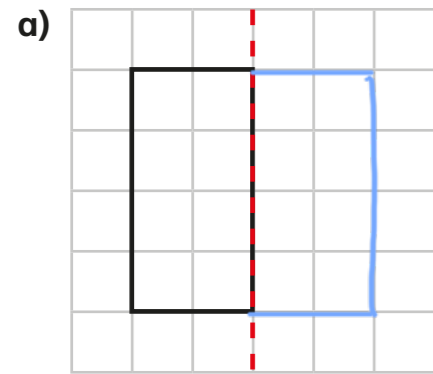

2 Reflect each shape in the mirror line.

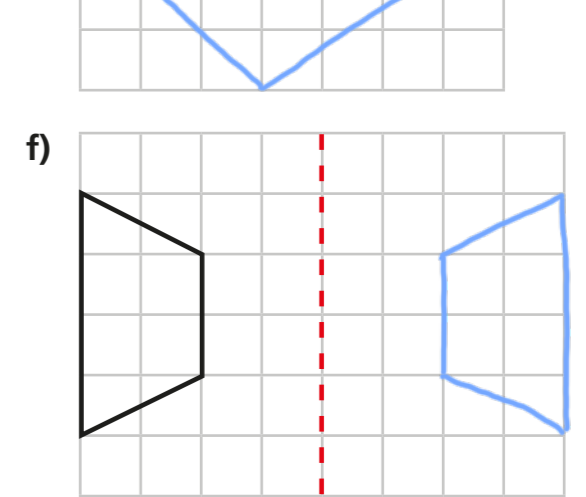
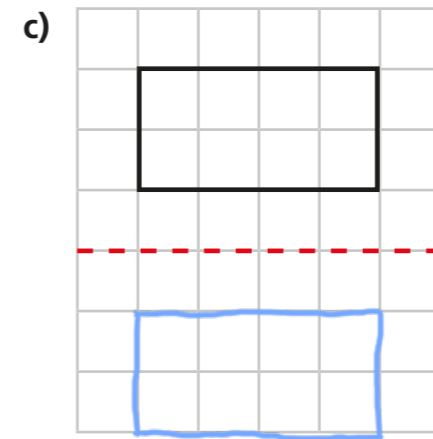
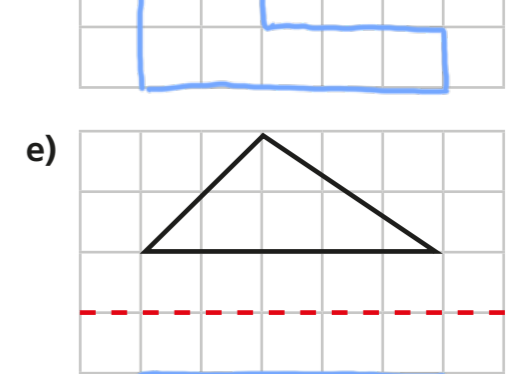
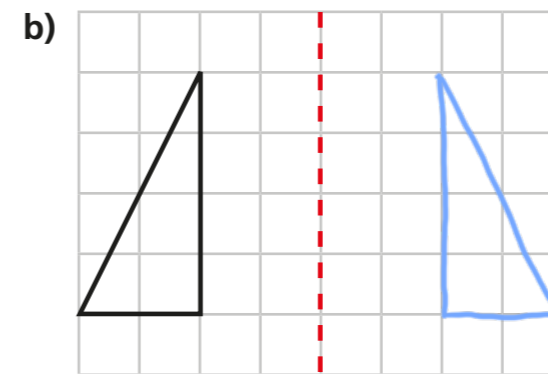
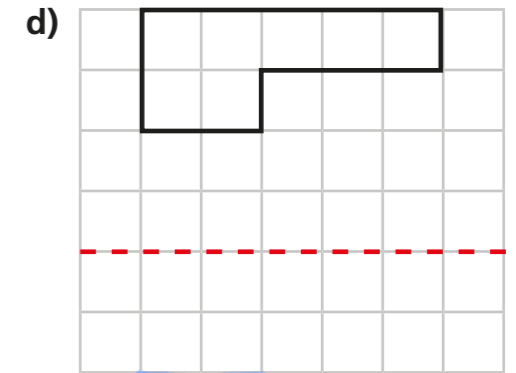
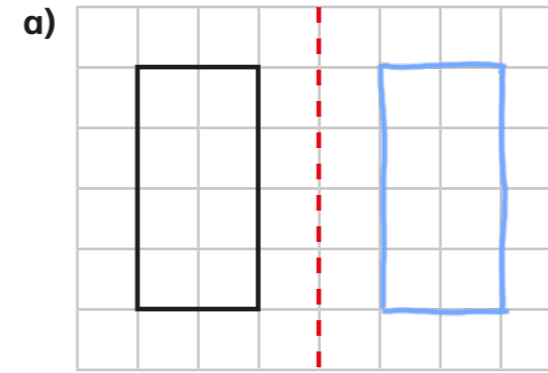

3 Which diagrams show a correct reflection in the given mirror line?

Tick your answers.

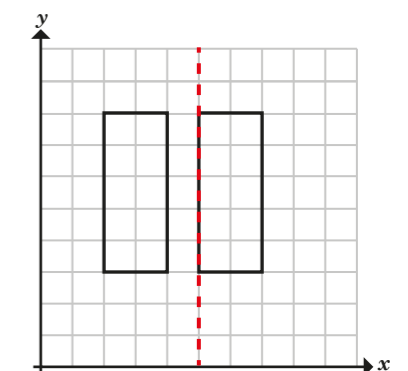
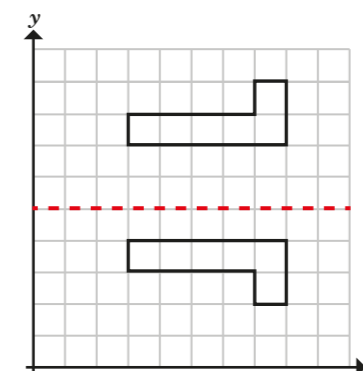
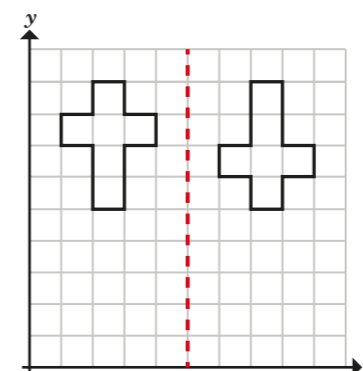

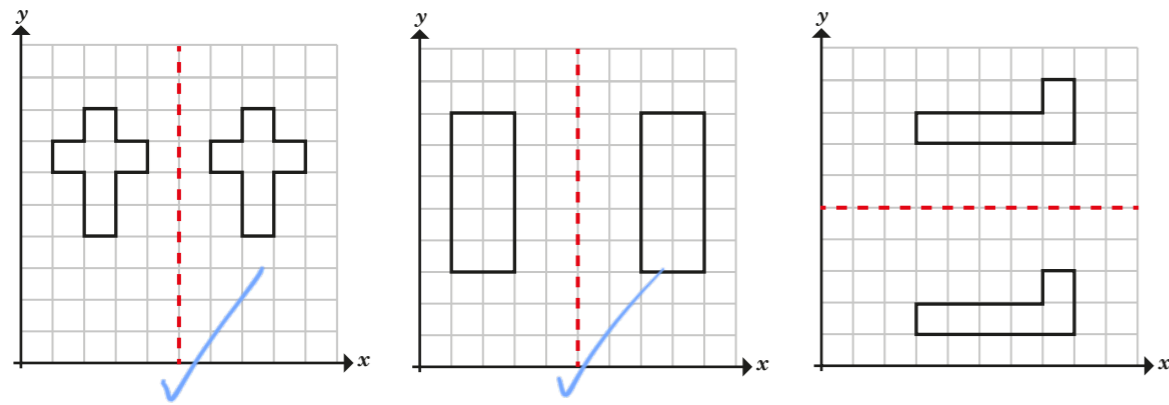

Talk to a partner about the mistakes that have been made.



4 Reflect the objects in the given mirror lines.

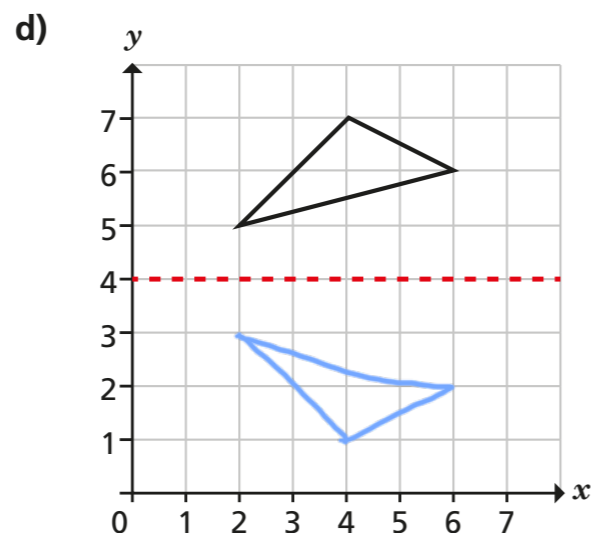
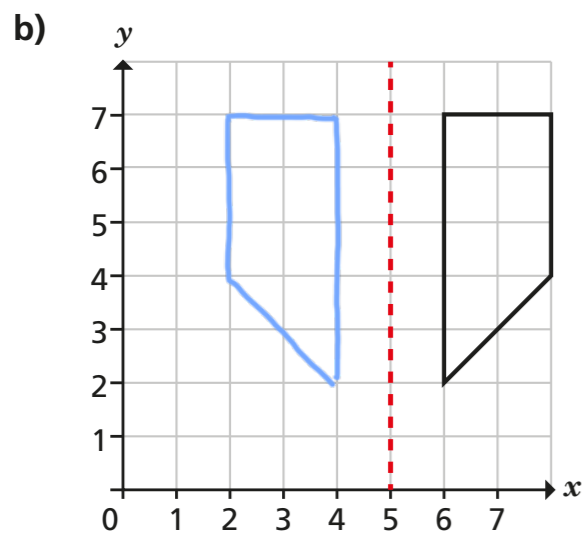
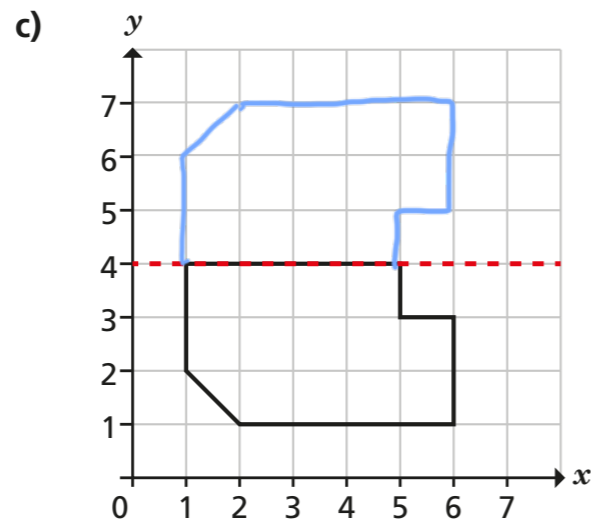
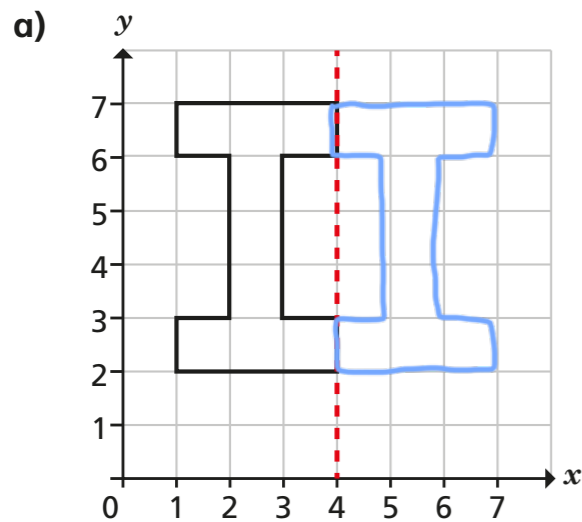

5 Five points are plotted on a coordinate grid.

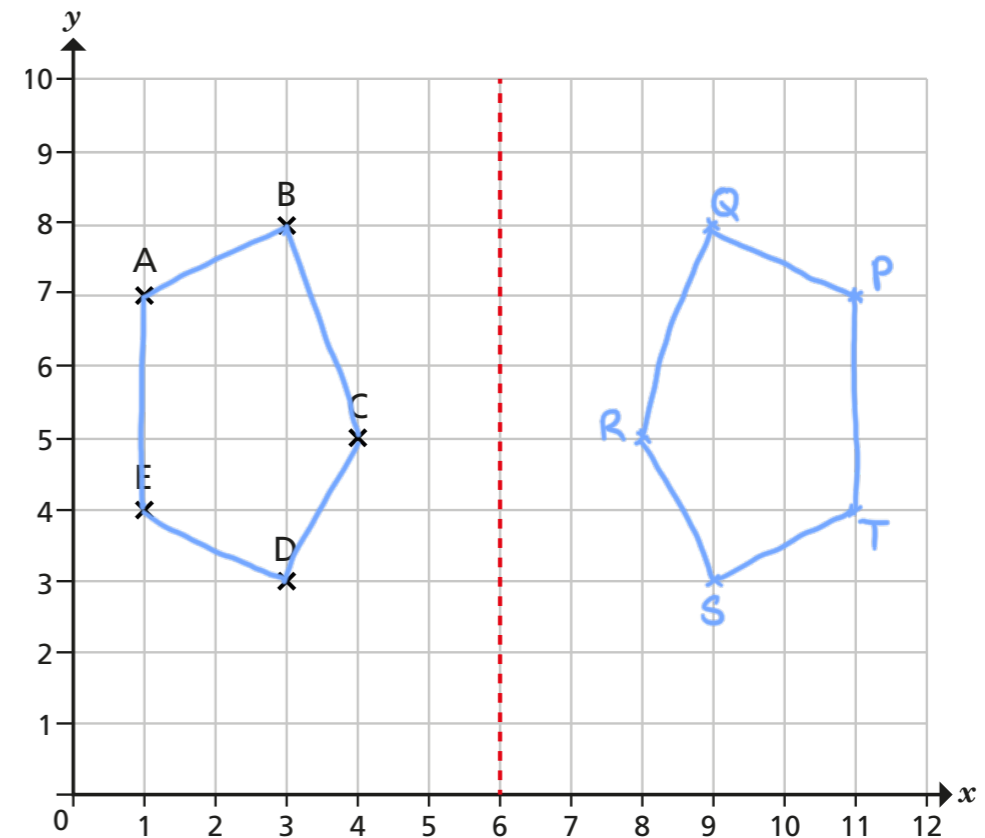

a) Join the points to form a polygon. This is the object.

What type of polygon is the object? pentagon

b) Reflect the object in the given mirror line.

What type of polygon is the image? pentagon

c) Label the reflected vertices P, Q, R, S and T.

Write the new coordinates.

P (11 , 7) Q (9 , 8) R (8 , 5)
 S (9 , 3) T (11 , 4)

d) The image and the object are identical polygons.

Is this statement true or false? True

Talk about it with a partner.



Translation



1 Complete the translations.

a) Translate the shape 4 squares to the right.

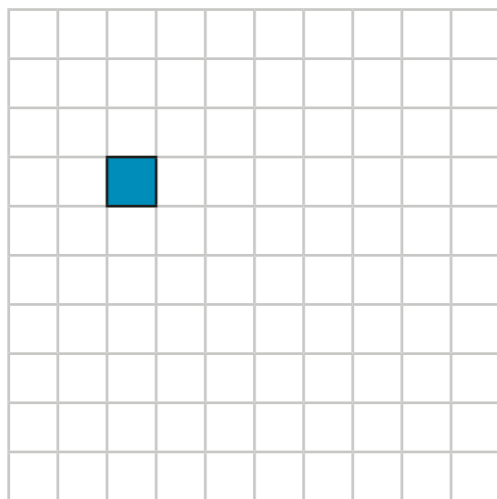

c) Translate the shape 4 squares right, 2 squares up.

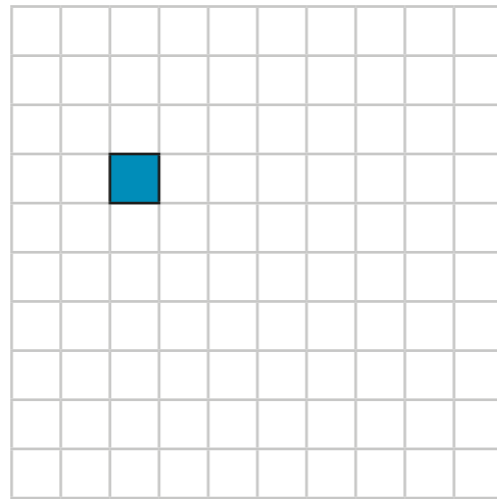

b) Translate the shape 2 squares up.

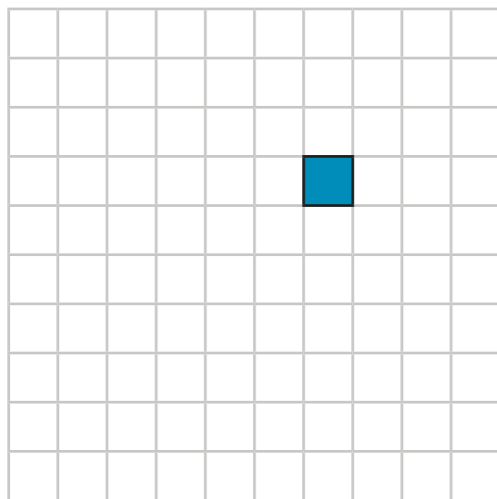

d) Translate the shape 3 squares left, 5 squares down.

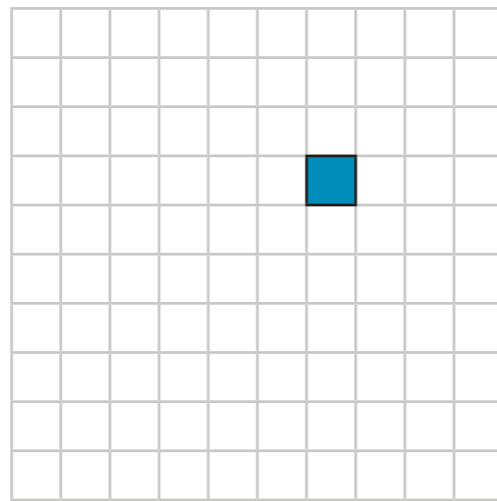

2 Four shapes have been drawn on a grid.

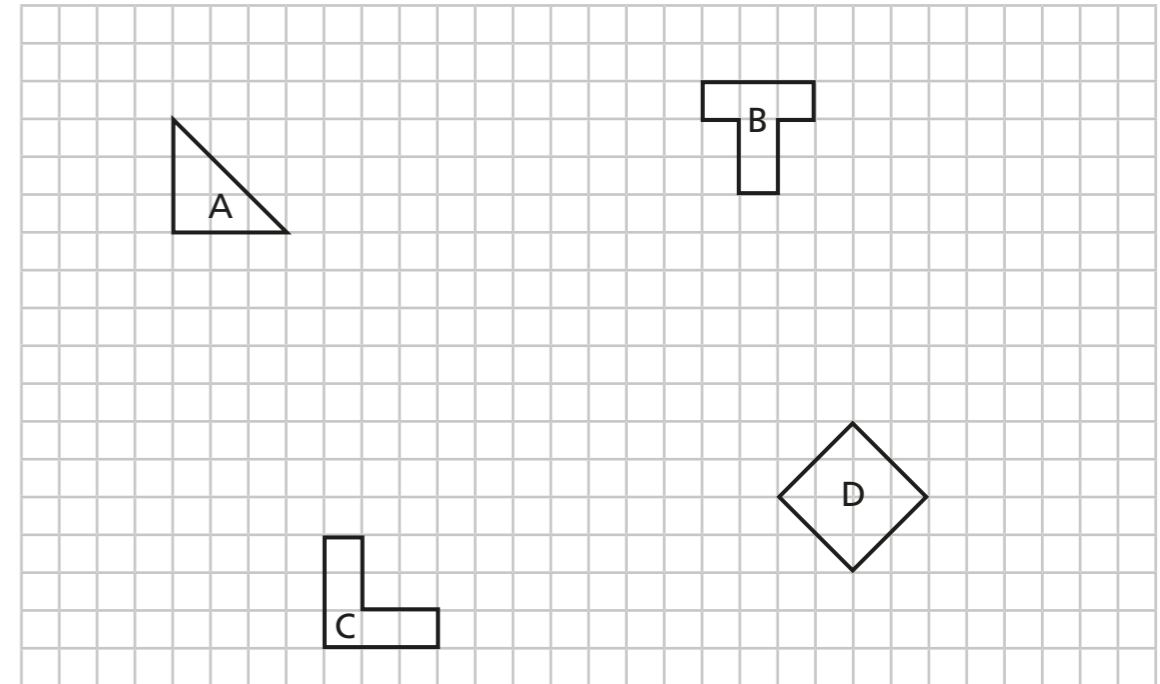

- a) Translate shape A 5 squares to the right and 3 squares down.
- b) Translate shape B 4 squares to the left and 7 squares down.
- c) Translate shape C 6 squares to the left.
- d) Translate shape D 4 squares to the right and 8 squares up.

3 Dora has translated triangle A 2 squares to the right and 7 squares up.

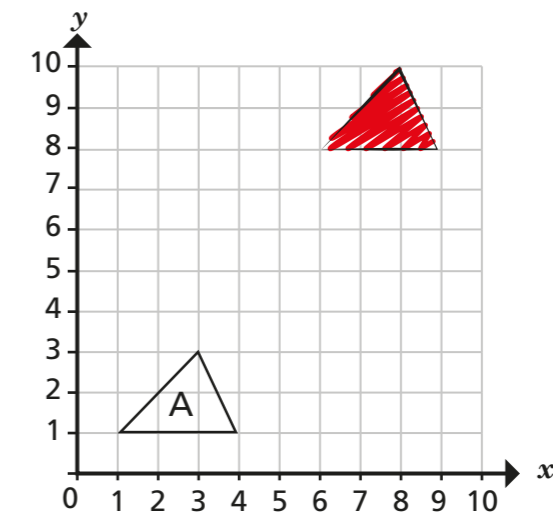

Is Dora's drawing correct? _____
Explain why.



4 Complete the sentences to describe the translations.

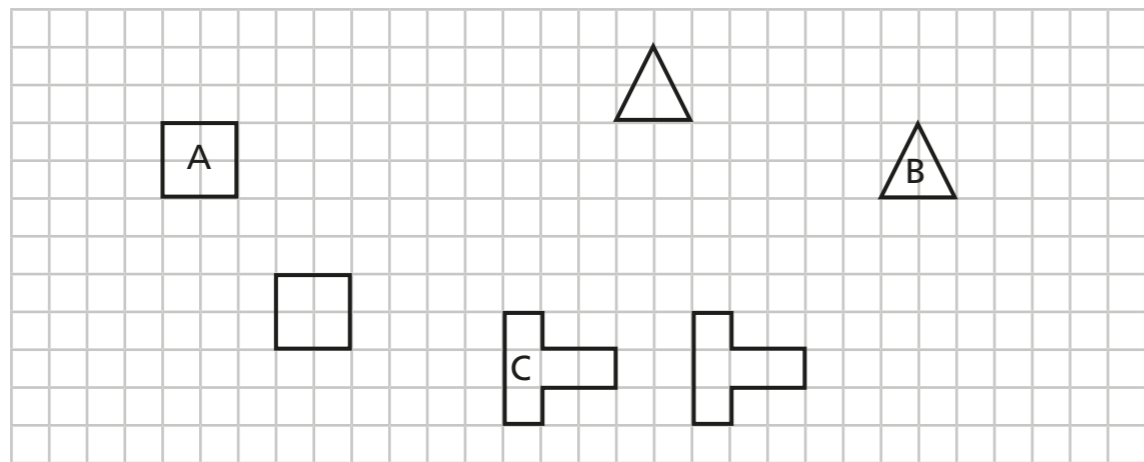

- a) Shape A has been translated squares to the right and squares down.
- b) Shape B has been translated squares to the left and squares up.
- c) Shape C has been translated squares to the right and squares up/down.

5 A shape has been drawn on a coordinate grid.

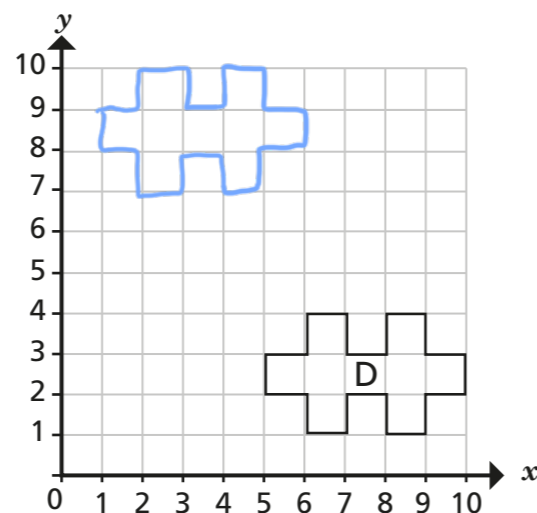

- a) Translate shape D 4 squares to the left and 6 squares up. Label the new shape E.
- b) Describe the translation from shape E to shape D.

4 squares to the right and 6 squares down

What do you notice? Does this always happen?

6 Eight polygons are drawn on the grid.

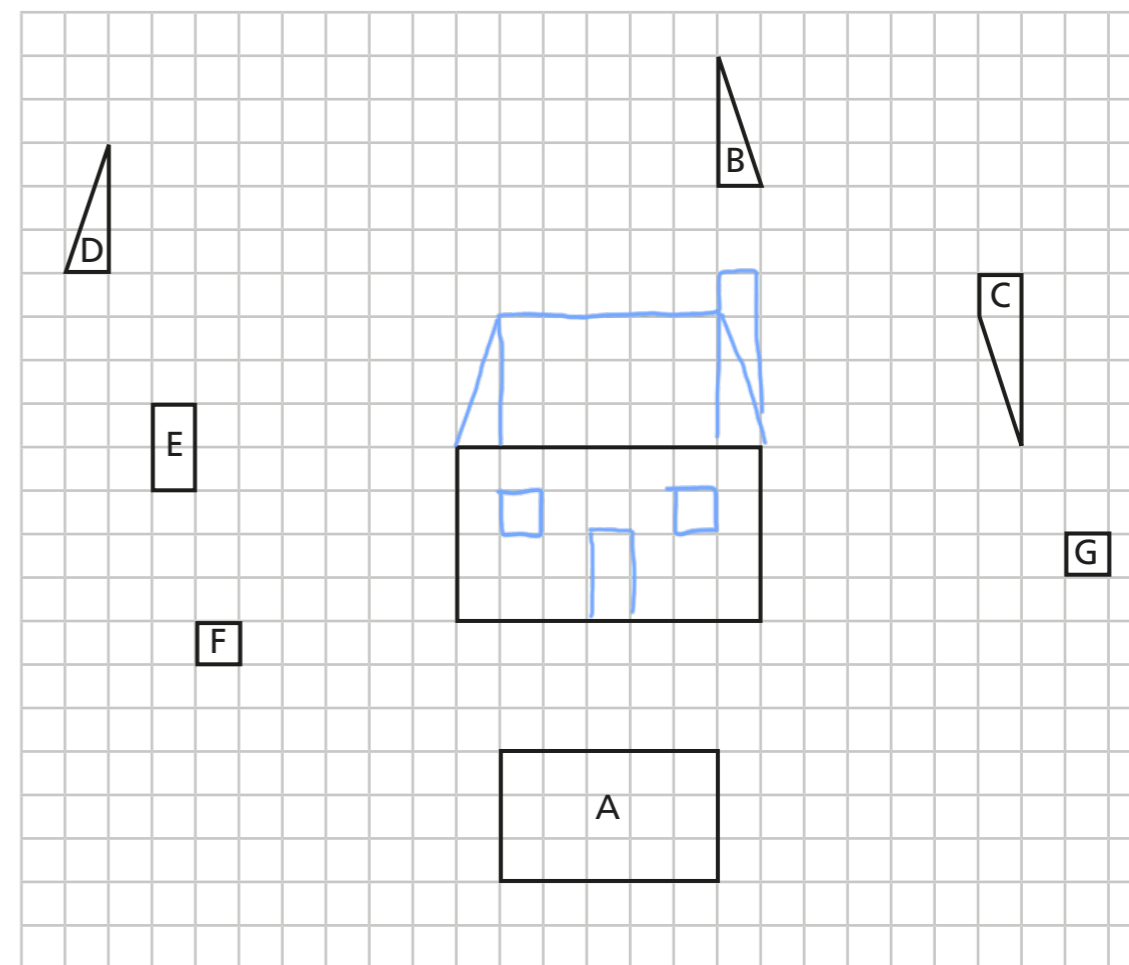

- a) Translate shape A 10 squares up.
- b) Translate shape B 6 squares down.
- c) Translate shape C 6 squares left.
- d) Translate shape D 9 squares to the right and 4 squares down.
- e) Translate shape E 10 squares to the right and 3 squares down.
- f) Translate shape F 7 squares to the right and 3 squares up.
- g) Translate shape G 9 squares to the left and 1 square up.

Create your own problem like this for a partner.

